

# CHEMISTRY & PHYSICS

Updated Oct. 2023

FIRST YEAR

SECOND YEAR

THIRD YEAR

FOURTH YEAR

FALL

WINTER

FALL

WINTER

FALL

WINTER

FALL

WINTER

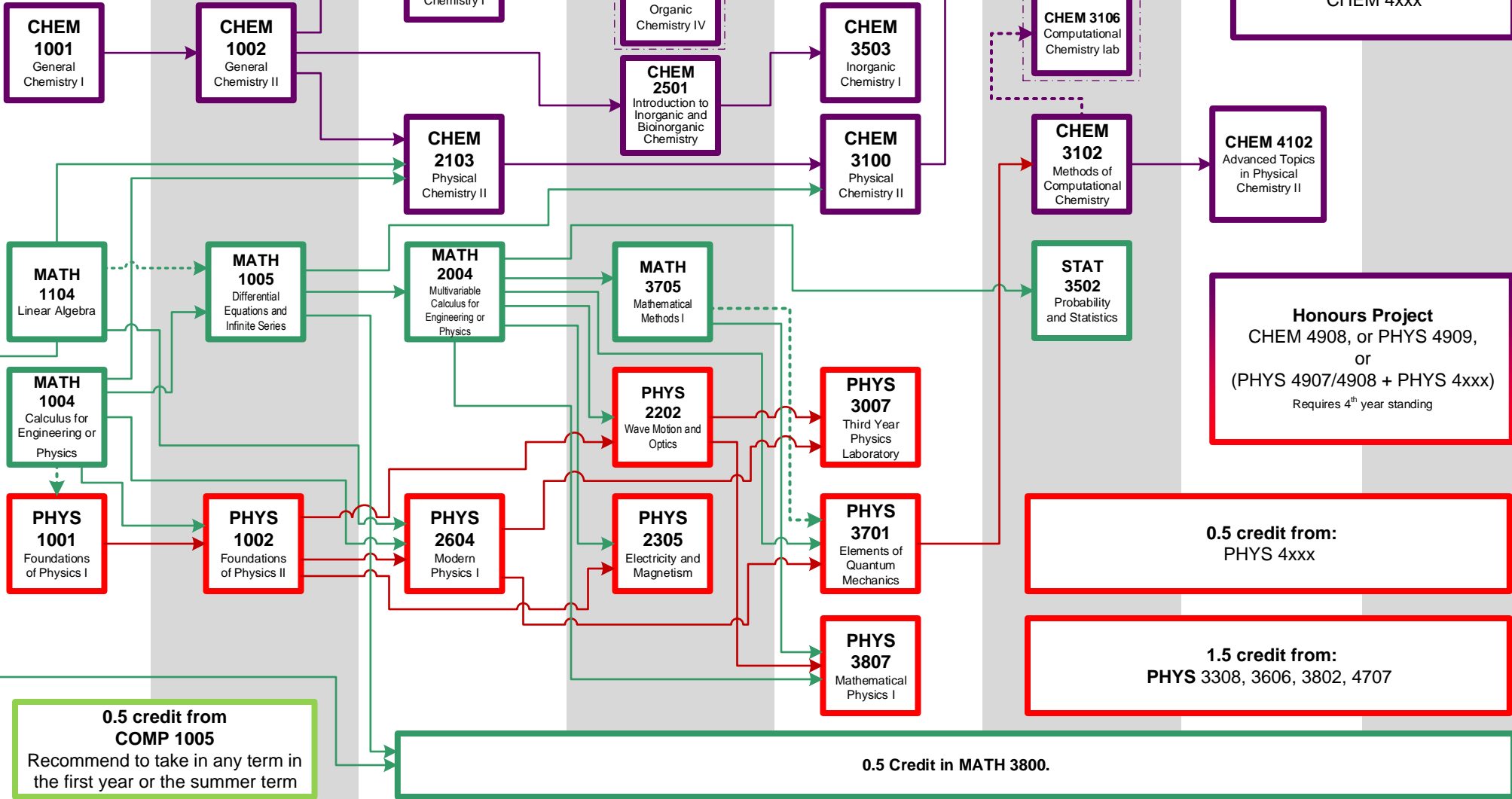

2.0 credits in Approved courses outside the faculties of Science and Engineering and Design, one of which can be NSCI 1000

Plus

1.0 credit in free electives

Note:

- Dashed connecting line indicate a pre-requisite that may be taken concurrently.
- Some Experimental Science, COMP, ELEC and MATH, and many elective courses are also offered in summer, which may help to reduce your course load in the Fall and Winter terms.